

Macurco™

BUILDING & HOME SOLUTIONS

Whether you are looking for gas detection for a security system, building automation, or HVAC system, for personal safety, or for monitoring specific gases in potentially hazardous environments, Macurco has a gas detector to meet your needs.



GD-2B (Combustible Gas)



GD-2A (Combustible Gas)

GD-2B & GD-2A

Residential / light commercial combustible gas detectors

The Macurco GD-2B and GD-2A combustible gas detectors are reliable, lightweight, and aesthetically pleasing gas detectors made to keep you and the people you care about safe from harmful gases in residential and light commercial applications. They are low-voltage gas detectors designed for use with fire and security systems. The GD-2A is UL 2075 Listed for use in residential and commercial applications and is also approved by the California State Fire Marshal.

Key Features

- UL 2075 Listed (GD-2A)
- Low replacement costs with long-life sensors
- Low maintenance with no calibration needed
- Local alarms (GD-2B only)
- Clip-in wire harness (GD-2B only) for in and out replacement
- Aesthetically pleasing. Flush mount or surface options
- Ties into any Fire/Burglary panel for local and remote monitoring
- Made in America

Applications

- Homes
- Schools/university dorms
- Hotels/condos
- Offices
- Retail stores
- Common rooms/lobbies
- Apartments
- Airports
- Other light commercial environments



GD-2B / GD-2A

Specifications

Size	GD-2B: 3.25"(H) x 5.25"(L) x 1.75"(W) GD-2A: 4.5"(H) x 5"(L) x 1.62"(W)
Shipping Weight	0.5 lb. (8 oz.)
Voltage	GD-2B: 9-32 VDC or 12-24 VAC GD-2A: 9-32 VDC or 12-24 VAC
Sensor Life	GD-2B: 5 years w/EOL GD-2A: 5 years w/EOL
Operating Temperature	32°F to 120°F (0°C to 48.9°C)
Current Draw	GD-2B, GD-2A - refer to manual, based on voltage and standby/alarm
Relays	GD-2B, GD-2A - refer to user manual
Status Indicators	GD-2B: LED (Red alarm, amber trouble, green normal) GD-2A: LED (Red alarm, green normal, alternating red/green trouble)
Local Buzzer	GD-2B: 85 dB at 10' Alarm - 2 chirp sequence, Trouble - single chirp GD-2A: NA
Alarm Levels	Per UL 1484, 25% LEL
Test Button	GD-2B: Local Test, Alarm Test, Gas Test, Silence GD-2A: NA
Approvals / Listings	GD-2B: Sensitivity tested based on UL 1484 GD-2A: UL 2075 Listed. Tested to 1484 standard for residential gas detectors
Warranty	Two year limited warranty

*Please read manual for more specifications

Ordering Information

Model	Description
GD-2B	Natural Gas (NG) or Propane (LP) Combustible Gas Detector
GD-2A	Natural Gas (NG) or Propane (LP) Combustible Gas Detector
CM-E1-IAK	Double Gang Adapter Plate used with the GD-2B

Wiring Diagrams

GD-2B Single Detector Wiring

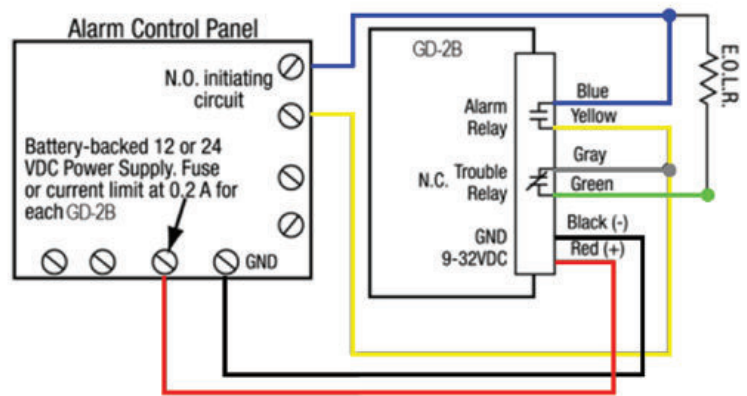

GD-2A Single Detector Wiring

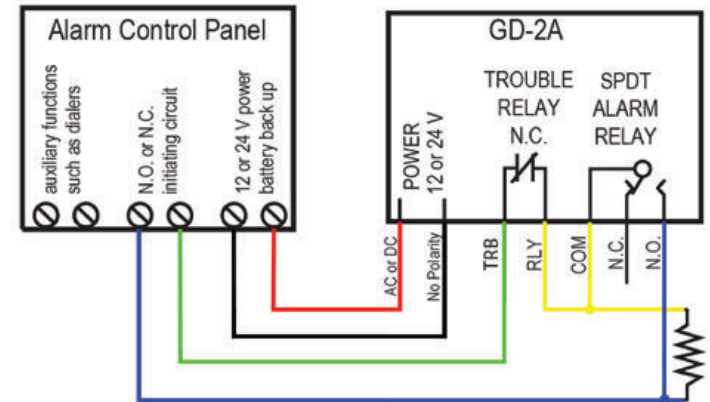

Since 1972 Macurco has been providing gas detection solutions for various applications. Macurco provides the highest quality gas detection solutions to customers worldwide.



Macurco Gas Detection
1504 W. 51st St,
Sioux Falls, SD 57105

Phone: 1-877-367-7891

Website: www.macurco.com

Email: Macurco_info@dwyeromega.com